



## io6 Installation Guide



# Thank you for choosing the io6

---

---

Ratio EV Charging  
Unit 1 Target Park  
Shawbank Road  
Lakeside  
Redditch  
Worcestershire  
United Kingdom  
B98 8YN

+44 (0) 1527 396 900

---

info@ratioev.uk  
sales@ratioev.uk  
technical@ratioev.uk

---

ratioev.uk

---

---

# Preface

---

## About this document

This manual contains technical descriptions and instructions for the following product:

Category of product	Charger for Electric Vehicles
Product name	io6
Art. No.	io6xxx
Hardware version	io6
Serial number:	
Bluetooth Password:	

Write down the serial number of your product in the table above for future reference.

This manual contains all instructions and safety information for installation, commissioning, use and maintenance of the product.

This manual is intended for:

- the qualified electrician who installs the product;
- the end-user who uses the charger;
- the product owner who maintains the product.

## Copyright

The content of this manual is protected by copyright and other intellectual property laws. The content of this manual may only be copied, modified, reproduce or translated with express written permission from the manufacturer. This manual may only be published, transmitted, displayed or made available to a third party with express written permission from the manufacturer.

## Disclaimer of liability

Ratio EV Charging cannot be held responsible for personal injury, damage to the product or property damage caused by incorrect use, foreseeable misuse or failure to follow the instructions in this manual. This also applies to unauthorized modifications of the product and the use of non-approved spare parts, tools or accessories.

Ratio EV Charging reserves the right to modify this manual without notification beforehand.

# Table of contents

---

Safety	5
Symbols and labels	5
Safety warnings	5
Fuel Identifier	5
Notices	6
Intended use	6
Reasonably foreseeable misuse	6
Qualification of personnel	7
Personal Protective Equipment	7
Product description	9
Charger Components	10
Sensor Box components (Optional for Smart charger)	11
Technical data	12
Product Labelling/Marking	13
Transport and Storage	13
Transport	13
Storage	13
Installation	13
Preparation	13
Check the contents	14
Required tools	15
Required wiring and electrical protection	15
Install the power cable in the distribution board	16
Install the Sensor Box in the consumer unit	16
Charger Installation/Mounting	19
Connect the power cable to the charger	20
Ethernet cable installation	24
Data cable installation	25
Install a data cable between two chargers for Power Sharing	27
In the Main Controller	27
In the Sub charger	28
Final installation checks	30
Finish the installation	31
Commissioning	32
The unique password of the charger	32
Download the Ratio EV Charging App	32
Initial configuration of the charger	32
Overview of the Ratio EV Charging App	34
Connect the charger to the Ratio EV Charging App	34
Testing solar charging functionality	35
Updating the charger	35
Using the io5	36
Start charging	36
During charging	37
Charging paused	37
Stop charging	37
Settings	37
Maintenance	39
Troubleshooting	40
Service	42
Data protection	42
Warranty	42
Disposal	42
EC Declaration of Conformity	43

# 1. Safety

---

Please make sure the instructions have been fully read and understood before commencing the installation or use of the product. Failure to follow the instructions from this manual can put people, surroundings, the environment and product at risk. Store this manual securely for future reference.



Always comply with the information, such as labels and the nameplate, attached directly to the product and keep the information in a legible condition.

Always comply with any applicable laws and regulations that have not been accounted for in this manual for example IET regulations.

## 1.1. Symbols and labels

### 1.1.1. Safety warnings

This manual contains safety warnings that may result in injury if ignored. Each safety warning is indicated with a safety identifier. The identifier corresponds with the level of risk of the described hazardous situation, see the table below.

Safety Identifier	Risk of injury	Result when instruction is ignored or not followed correctly
 <b>WARNING</b>	Medium	Could result in death or serious injury
 <b>CAUTION</b>	Low	Could result in minor or moderate injury

Safety warnings at the start of a section apply to the entire section.

Safety warnings that refer to a particular sentence or procedure step are embedded in the running text.

### 1.1.2. Fuel Identifier



Fuel Identifier

The Fuel Identifier is there to inform the user the fuel type used (electricity) by this charger and to instruct which end of the cable is to be plugged into the socket or vehicle inlet.

**For Socket versions of io6** - The Fuel Identifier symbol is located at the front of the charger by the socket. The socket on the io6 receives the Plug end of charging cables which should be indicated with a smaller similar graphical illustration. This will be either silver or white in colour.

**For Tethered versions of io6** - The Fuel Identifier label on this version will be located on the vehicle connector.

**Charging cable** - Charging cables will have a small white/silver Fuel Identifier on the plug side to indicate this is compatible with the socket, and a black Fuel Identifier on the vehicle connector to specify this end is to be plugged into the vehicle inlet.

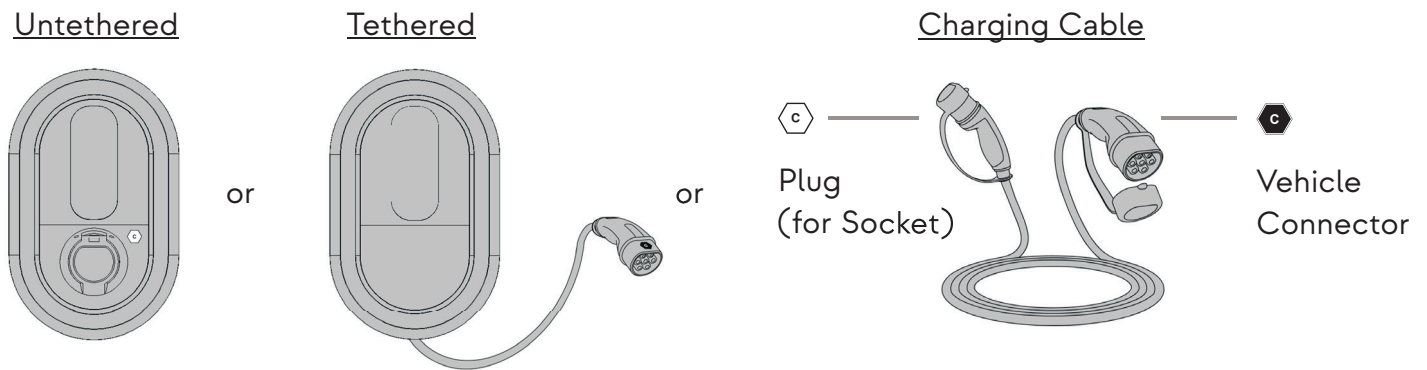

### 1.1.3. Notices

Messages that are not hazard-related are indicated with the safety identifier **NOTICE**. These messages do not have a safety alert symbol.

Signal word	Meaning
<b>NOTICE</b>	Could result in damage to the product when instruction is ignored or not followed correctly.
<b>Note</b>	Additional information or emphasis on an instruction.

## 1.2. Intended use

The Ratio io6 Charger is both a non-restricted and restricted charger intended to charge electric vehicles using power from solar panels and household power grid. The product can be operated indoors and outdoors.

The product must only be operated within its performance limits and under the permitted ambient conditions, as stated in the technical specifications in chapter 3.

The product can be mounted flush to a wall or to a separately available pole.

Safe use of the product is only guaranteed if it is used as intended.

## 1.3. Reasonably foreseeable misuse

The following is considered foreseeable misuse:

- Use in an environment that varies from or exceeds the given environmental conditions.
- Use that varies from or exceeds the given operating conditions.

- Failure to comply with the instructions in this manual.
- Failure to eliminate faults, malfunctions or defects of the product that impose safety risks.
- Failure to carry out the inspections and maintenance operations as described in this manual.
- Unauthorised removal or modification of parts or safety devices of the product.
- Use of spare parts or accessories that have not been approved by the manufacturer.
- Operation in a flammable and/or explosive environment.
- Operation in closed-off or poorly ventilated rooms.

## 1.4. Qualification of personnel

Only authorised electricians are allowed to perform installation and maintenance of the product. They must meet the below stated criteria:

- are of legal age.
- are familiar and abide by the safety instructions and sections of this manual related to installation and maintenance of the product.
- are familiar with and abide by the applicable local, national and international laws and regulations.
- are able to recognise the possible dangers of the product and take the necessary measures to protect persons and property.
- have received adequate training in the safe installation and maintenance of this product.
- hold the relevant qualifications.

## 1.5. Personal Protective Equipment

**NOTICE** Wear the appropriate Personal Protective Equipment (PPE) according to the manual of any tools used during installation of the charger.

Wear insulating gloves when installing wires and touching electrical components to avoid damaging the product by static discharge.

## 1.6. Safety precautions

Despite the safe design and construction of the product and the prescribed protective measures, the product possesses residual risks. This manual provides safety messages to indicate these risks. The formatting and appearance of safety messages that are dedicated to a particular section or sentence is explained in chapter 1.1.

Read all the safety warnings and instructions before using the product. Failure to follow the warnings and the instructions may result in electric shock, fire and/or serious injury.

### **⚠ WARNING**

- Do not put fingers into the electric vehicle connector.
- Do not use this product if the flexible power cord or EV cable are frayed, have broken insulation, or show any other signs of damage.

- Do not use the product if the enclosure or EV connector are broken, cracked, open, or show any other indication of damage.
- The electrical installation must be isolated during the entire installation period.
- Improper connection of equipment-grounding conductor can result in a risk of electric shock. Check with a qualified electrician or serviceman if you doubt whether the product is properly grounded.
- Do not use this product if it not functioning according to the instructions in this manual. Seek advice from Ratio, your vendor, or a qualified electrician or service agent.
- Do not attempt to remove the charging plug while a charging session is active.
- Children should not be allowed to use this product. Do not allow children to play near the product. Children should be supervised when using this device around them.
- The installation must be conducted by a qualified electrician in line with local and national legislation and IET regulation.
- Open PEN fault protection is incorporated into single phase io6 charger variants.
- For three-phase io6 charger variants open PEN fault protection is not integral to the charger. A third party open PEN device or an earth electrode should be installed as per IET regulations.

#### **⚠ CAUTION**

- Ensure the supply cable of the product is positioned so it will not be stepped on, tripped over, or otherwise subjected to damage or stress.
- There are no user serviceable parts inside. Refer to the Customer Support section in this manual for service information. Do not attempt to repair or service the product yourself.
- Do not operate this product if it or the supply cable or housing is visibly damaged. Isolate the supply in the electrical cabinet and contact your Service Representative for service immediately. Refer to the Customer Support section in the manual for information on the Service Representative in your area.
- Only use this product to charge electric vehicles equipped with a conductive charge port. See the vehicle owner's handbook to determine the vehicle is equipped with a conductive charge port.
- Use of any adaptors is not allowed with this product.
- Only use certified Type 2 charging cables with this product.
- Cord extension sets are not allowed to be used.

#### **NOTICE**

- Do not drop the product and avoid impacts.
- Do not store the product in an environment that exceeds the ambient conditions stated in this manual.
- Do not expose the internal components of the product to moisture.
- Do not immerse the product in water or any other liquid.

## 2. Product description

---

The io6 is a Mode 3 charger for charging electric vehicles (EVs) which complies with the IEC61851 series of standards.

The io6 is equipped with several features to optimise power consumption and charging performance.

### Dynamic Load balancing

The product uses a Sensor Box with Current Transformer(s) (CT) to measure the live power consumption of the power grid per phase and uses that information to manage the power output to the EV. When more electrical appliances are used, the power output to the EV is reduced to avoid overloading the local power grid.

### Power Sharing

If more than one charger has been purchased, they can be interconnected with a data cable and use the integrated **Power Sharing** feature to equally distribute the available power across the charge points using the data from the Sensor Box.

The Sensor Box uses up to three CT clamps, one for each phase of the main grid, to measure the current flow of the main grid. The Sensor Box is also compatible with solar panel installations and can measure the direction of the current.

One charger is connected to the Sensor Box with a data cable. This charger acts as the Main Controller (MAIN), and manages the power for up to three Sub Chargers (SUB1, SUB2 and SUB3).

It is also possible to use Power Sharing without the Sensor Box. The charger will function without Dynamic Load Balancing, but the chargers must still be connected to each other with a data cable and set in Basic mode.

**Note:** Pure Solar mode is not compatible with **Power Sharing**.

### Over the air (OTA) updates

The io6 charger is equipped with the technology to receive over the air updates, enabling your charger to receive the available updates over the internet.

### Ratio EV Charging App

The charger can be controlled with the Ratio EV Charging App. The App is available in the Google Play store and Apple store.

### Multiple users and multiple cars

Different users and multiple cars can be added to view the charging sessions of each individual online. A maximum of five users or cars can be created.

## Charge modes

The charger has four available charge modes:

---

<b>Basic</b>	The charger charges the EV using a set maximum current in Amps (Maximum charging current). - no Load Balancing
<b>Smart</b>	The charger only charges the EV when the available current is above the minimum set current in Amps (Minimum charging current) and below the maximum current that is still available on the main grid. *
<b>SmartSolar</b>	The charger only charges the EV when the available current is above the minimum set current in Amps (SmartSolar minimal charging current) and below the maximum current that is still available on the main grid. If the charger is charging the EV and there is still net current generation, the charger uses this surplus of energy to charge the car in addition to the minimum set current. *
<b>PureSolar</b>	The charger only charges the EV when there is a net current generation (e.g. from solar panels), that is above the minimum set current in Amps (PureSolar minimal charging current). *
<b>Back end</b>	Charging can also be configured through the back-end software such as Monta or Fuuse. These will commonly be private, public or schedule.

---

\* Charging at a maximum current while protecting the building from over current loading with Dynamic Load Balancing. While charging at home or commercial facility, the charging current adapts to the maximum allowed consumption in the building.

**Note:** PureSolar mode is not compatible with **Power Sharing**. If you set the charge mode to PureSolar, **Power Sharing** will be disabled.

## 2.1. Charger Components

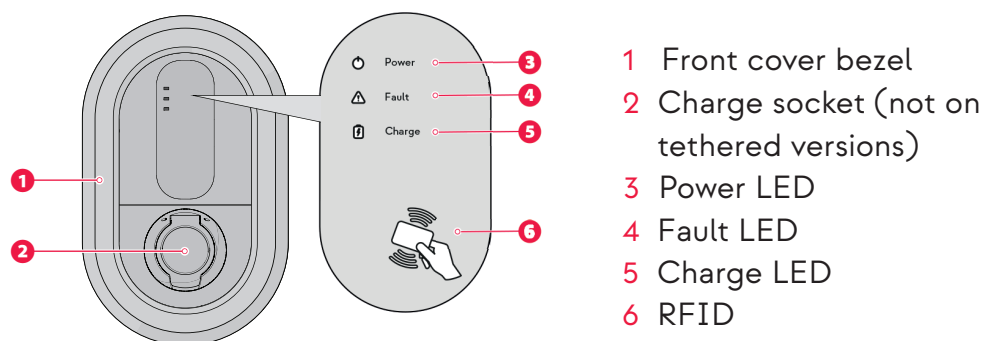

---

---

## 2.2. Sensor Box components (Optional for Smart charger)

**Note:** The io6 does not include the CT clamps and Sensor Box needed for Dynamic Load Balancing and PV charging. To upgrade your io6 to support Dynamic Load Balancing, a Sensor Box kit will need to be purchased. This package contains a Sensor Box, CT clamps, Mains input cable and an adhesive strip for mounting. Follow the instructions in chapter 5.3. of this manual to install a Sensor Box in your io6.

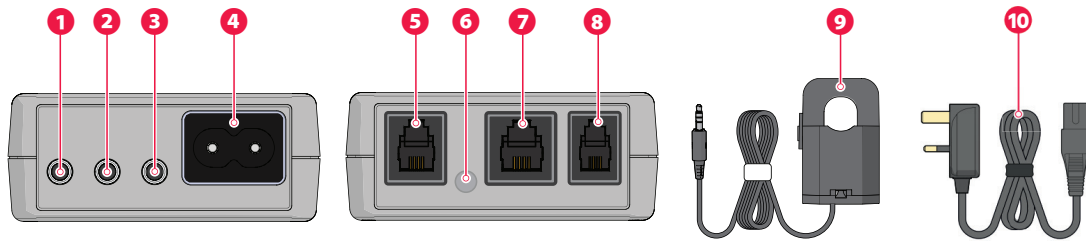

- 1 Phase 1 (L1) CT clamp input
- 2 Phase 2 (L2) CT clamp input
- 3 Phase 3 (L3) CT clamp input
- 4 Mains input \*
- 5 P1 meter input (inactive)
- 6 Status LED
- 7 Input/Output \*\*
- 8 Data cable connector
- 9 CT clamp (3 x for 3-phase installation, 1 x for 1-phase installation)
- 10 Plug

\* The mains input does not supply power to the Sensor Box. It is used to determine the direction of the measured current. The provided mains input cable must be installed on phase 1 (L1) of the main power grid and is orientation sensitive.

\*\* Not for Ethernet connection.

**Note:** It is advised to check the voltage of the Sensor Box via the Ratio app. This should supply a positive figure in the U1 box within the “Measured Values” in the Ratio app.

### 3. Technical data

<b>Product name</b>	io6	
<b>Art. no.</b>	io6xxx	
<b>Charging System</b>	IEC61851, Mode 3	
<b>Cable version car connector</b>	IEC 62196, Type 2	
<b>Outlet version</b>	IEC 62196, Type 2 Outlet	
<b>Power input</b>	Single-phase or three-phase, 230V-400V AC, 16A-32A	
<b>Max Power output</b>	output 7,4 kW / 230V AC, 22 kW / 400V AC	
<b>Frequency</b>	50 Hz	
<b>Protection against electric shock</b>	Class I	
<b>Residual current detection</b>	DC 6mA	
<b>Pen fault detection</b>	Single phase only	
<b>Dimensions</b>	400mm × 250mm × 105mm	
<b>Housing</b>	PC/ABS-V0	
<b>Weight</b>	4kg (incl. cable)	
<b>IP Protection rating</b>	IP54	
<b>Ambient temperature</b>	-25°C to +40°C	
<b>Markings</b>	CE & UKCA	
<b>Ventilation</b>	Not supported	
<b>Required protection device type</b>	Type A	
<b>Supported connectivity protocols</b>	Bluetooth® wireless technology	
	Wi-Fi	
	Ethernet	
	4G	
	RFID	
<b>Metering</b>	Onboard Metering	
<b>Metering Accuracy</b>	>96%	
<b>Standards</b>	BS EN IEC 61851-1	
	BS EN 62196	
	BS 7671:2018+A2:2022	
<b>EV Communications</b>	OCPP 1.6J	

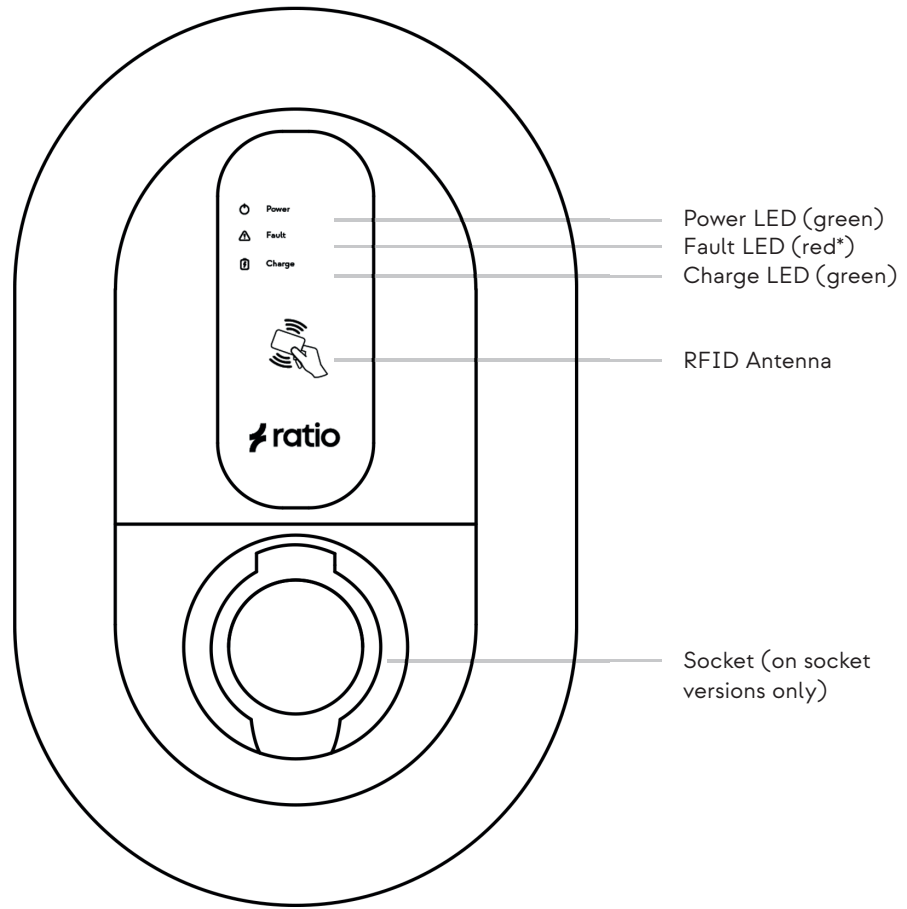

\* Faults will be displayed in the Ratio App or back-end software.

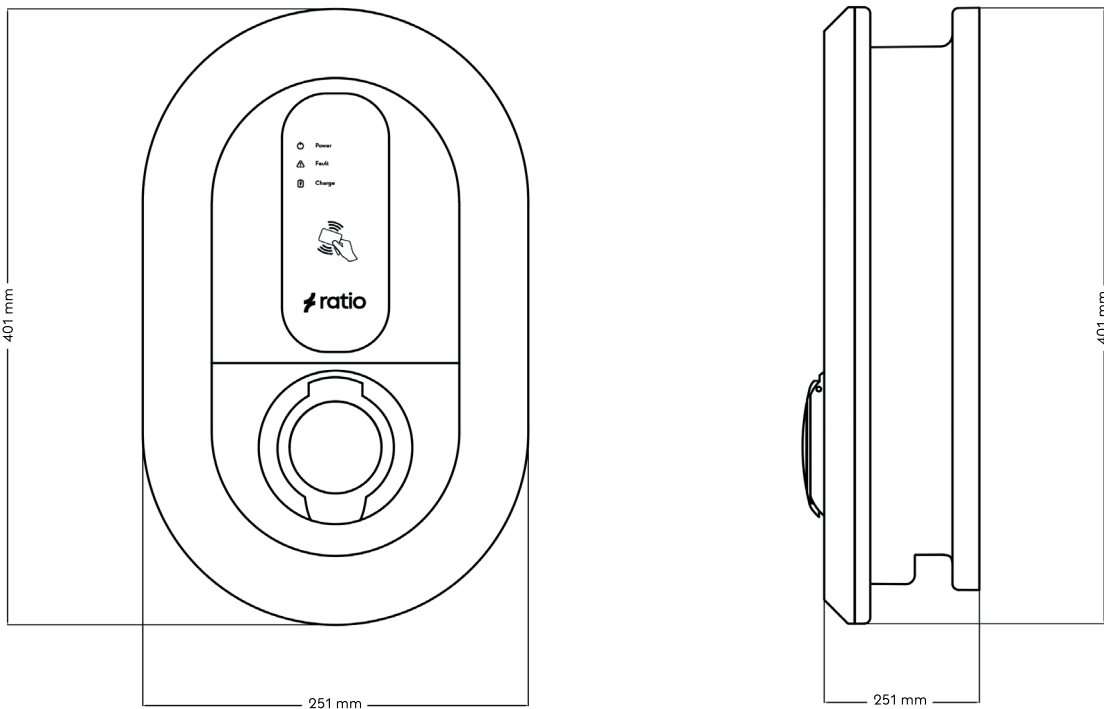

### 3.1. Product Labelling/Marking

The product is marked in accordance with the applicable legislative requirements. The product labelling/markings is located on the bottom of the housing, above the cable inlets.

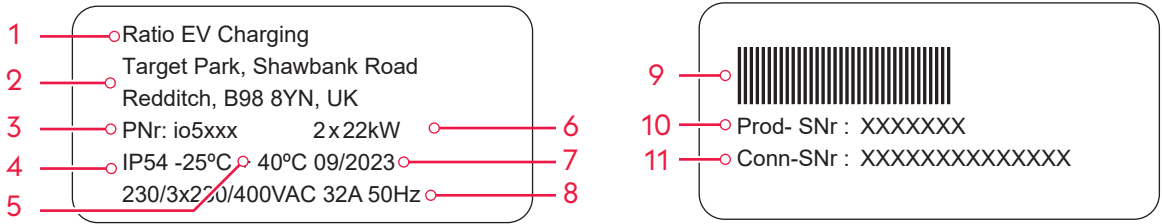

- 1 Manufacturer
- 2 Contact details
- 3 Product number
- 4 IP rating
- 5 Ambient temperature range
- 6 Product name
- 7 Production date
- 8 Rated input power & frequency
- 9 Barcode serial number
- 10 Product serial number
- 11 Connectivity serial number (visible in App)

## 4. Transport and Storage

### 4.1. Transport

Transport the product in the original packaging, or suitable replacement packaging that provides adequate protection from vibrations, impacts, moisture, dust, and debris. Ensure to not drop the product and prevent it from impacts. Excessive vibrations could loosen connections and cause product malfunction.

### 4.2. Storage

Store the product in the original packaging or a suitable replacement packaging to protect the product from moisture, dust, and debris.

Do not store anything on top of the product.

## 5. Installation

### 5.1. Preparation

**⚠ WARNING**

- The installation must be done by a qualified electrician in accordance with local and national legislation and IET regulations.
- The electrical installation must be isolated during the entire installation period.
- Since this charging unit uses circuits that reference to ground, no insulation resistance testing should be conducted on the unit after connecting to the supply network.

## 5.1.1. Check the contents



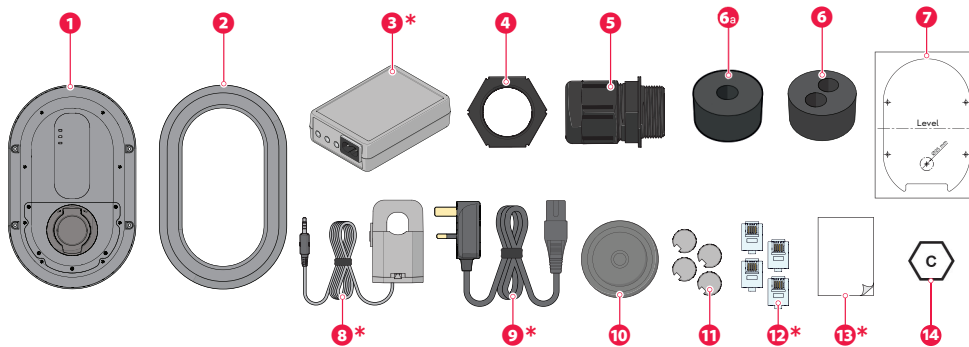

1. Open the box and remove the contents.
2. Place all parts on an empty surface to avoid losing any parts.
3. Check if all parts are present and undamaged using the overview below. In case of any parts missing or damaged, please contact your local dealer or Ratio EV Charging.

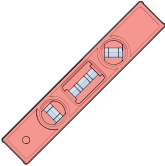
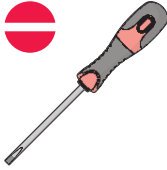

\* These parts are not included with the io6 charger.

- |    |                                       |    |  |
|----|---------------------------------------|----|--|
| 1  | Charger                               | 7  | Drilling template  |
| 2  | Frame                                 | 8  | Current transformers*<br>(x3 for three-phase installation) |
| 3  | Sensor Box with connector*            | 9  | Mains input cable for Sensor Box*                          |
| 4  | Locknut for cable gland               | 10 | Rubber grommet for data cable                              |
| 5  | M25 cable gland (x2)                  | 11 | Screw caps (x4)  |
| 6a | Single hole insert<br>for data cables | 12 | RJ10 connector (x4)  |
| 6b | Double hole insert<br>for data cable  | 13 | Adhesive strip*  |
|    |                                       | 14 | Fuel Identifier Label (socket versions)                    |

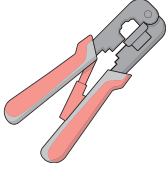
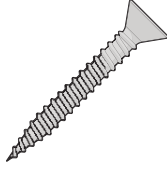
## 5.1.2. Required tools

		
Spirit level	Size 3 flat-head Screwdriver	T15 Torx
		
RJ10 Crimping tool	4 x 35 mm Screws	4 x Rawl plugs (if applicable)

\* The above tools are not included with the charger.

## 5.1.3. Required wiring and electrical protection

### Data cable

Shielded UTP cable or 4 x 0.25 mm<sup>2</sup> cable

Version	Wiring <sup>1</sup>	Protection Option 1		Protection Option 2
		Miniature Circuit Breaker (MCB)	Residual Current Device (RCD) <sup>2</sup>	RCBO <sup>3</sup> - Residual current Breaker with Over-current
16A / 1 Phase	3 G 2.50mm <sup>2</sup>	20A B/C-Curve	Type A, DP	20A B/C Curve, Type A, DP
16A / 3 Phase	5 G 2.50mm <sup>2</sup>	20A B/C-Curve	Type A, 3P+N	20A B/C Curve, Type A, 3P+N
32A / 1 Phase	3 G 6.00mm <sup>2</sup>	40A B/C-Curve	Type A, DP	40A B/C Curve, Type A, DP
32A / 3 Phase	5 G 6.00mm <sup>2</sup>	40A B/C-Curve	Type A, 3P+N	40A B/C Curve, Type A, 3P+N

Select Protection Option 1 **or** 2 from the above table.

- 1 - For cable lengths up to 25m. For longer cable lengths refer to IET regulations.
- 2 - Ensure RCD is compliant with BS EN 61008-1 and switches all poles (including neutral).
- 3 - Ensure RCBO is compliant with BS EN 61009-1 and switches all poles (including neutral).

## 5.2. Install the power cable in the distribution board

1. The electrical installation must be isolated during the entire installation period. Do not use the io6 until the installation has been completed.
2. Lay down a power cable and data cable between the distribution board and the installation location of the charger.
3. It is advised to connect the charger to your internet network with an Ethernet cable instead of using Wi-Fi. Therefore, install an Ethernet cable between your internet modem and the charger.
4. For circuit protection devices please refer to section 5.1.3.
5. Connect the power cable wires to the dedicated protection devices in the distribution board.

## 5.3. Install the Sensor Box in the consumer unit

If not applicable, please refer to section 5.4.

1. Mount the Sensor Box to a free location in the meter cupboard.
2. Plug the mains input cable into the Sensor Box.
3. Plug the other end of the mains input cable into a power outlet connected to the same phase as L1 of the charger.

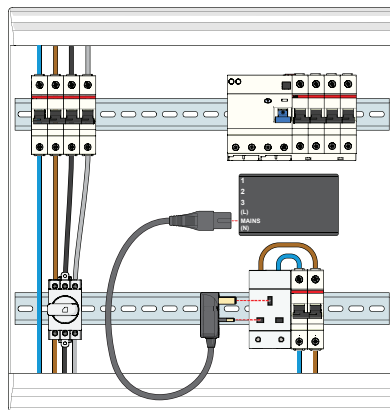

**Note:** The mains input is polarity sensitive. If the mains plug is inserted upside down, the measurements of the Sensor Box will be inaccurate. Check the markings on the Sensor Box for the correct polarity, check the correct position of L and N.

For polarity information, please refer to section 2.2.

4. Check on which phase of the main power grid the power outlet is connected.
5. Place a current transformer around the same phase wire of the main power grid, between the main fuse and the consumer unit.
6. Insert the 3.5mm jack of the current transformer to the L1 input on the Sensor Box.

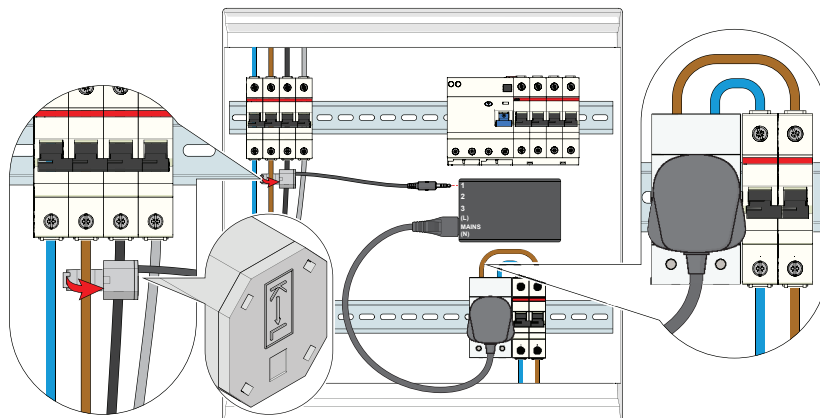

**Note:** For correct functioning of the Sensor Box, you must install this current transformer around the same phase as the power supply (L).

**Note:** Make sure the arrow on the current transformer points towards the entry point of the main power grid. See the image below for more information on the correct mounting location of the CT clamps.

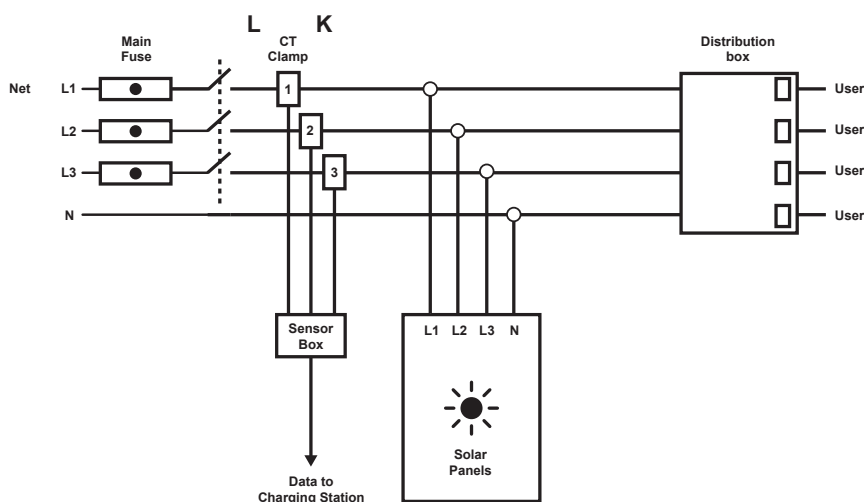

**Note:** For single-phase installations only install CT clamp 1 and connect to L1 position on Sensor Box.

7. Place the remaining current transformers around the other phase wires of the main power grid, and also between the main fuse and the consumer unit/solar panel connections. Ensure the arrow within the CT clamp is pointing towards the main fuse.

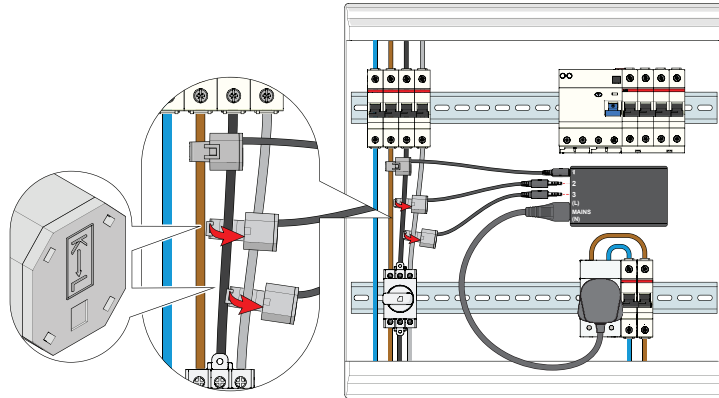

8. Insert the 3.5mm jacks of the current transformers to the L2 and L3 input on the Sensor Box.  
9. Strip the wires of the data cable (not included).  
10. Insert four wires of the data cable into the RJ10 connector.

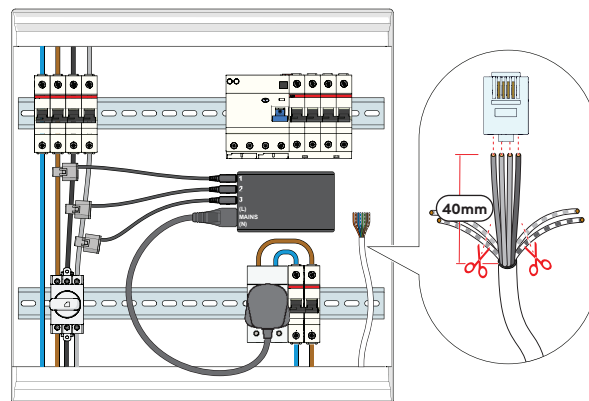

11. Secure the wires to the RJ10 connector. Use a RJ10 crimping tool.  
12. Write down the colours and order of the inserted wires of the data cable.

13. Insert the RJ10 connector into the Sensor Box.

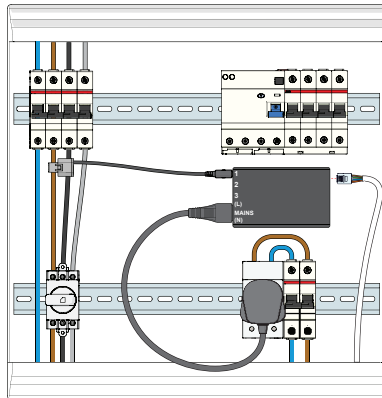

## 5.4. Charger Installation/Mounting

1. Tape the provided drilling template to the wall at the installation location, with the bottom of the template about 80-100cm above the ground.
2. Ensure the template is level. Use a spirit level.

### Alternatively

1. Hold the charger against the wall at the installation location, with the bottom of the charger about 80-100cm above the ground.
2. Ensure the charger is level. Use a spirit level.

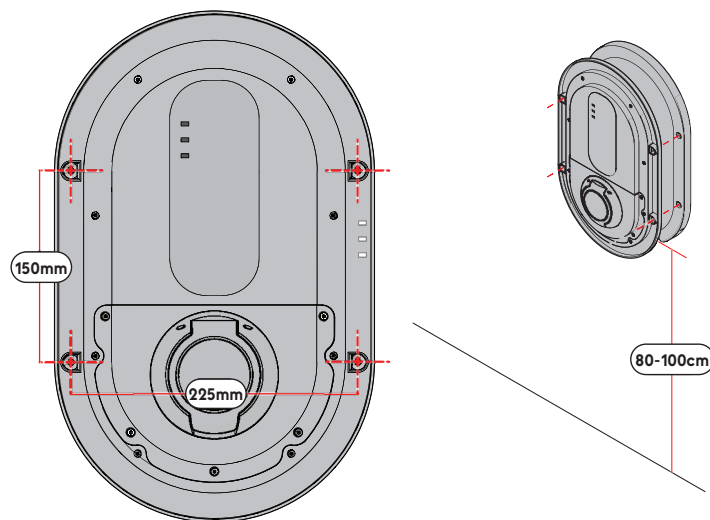

3. Mark the locations of the holes in the charger housing on the wall.
  4. Carefully remove the charger and lay it on a flat, stable and dry surface.
- 

5. Drill the holes in the wall. Use an appropriate drill and drill bit.
6. Insert rawl plugs (not included) if applicable.
7. Align the charger with the holes in the wall and secure it with four 5 x 35mm screws (not included).

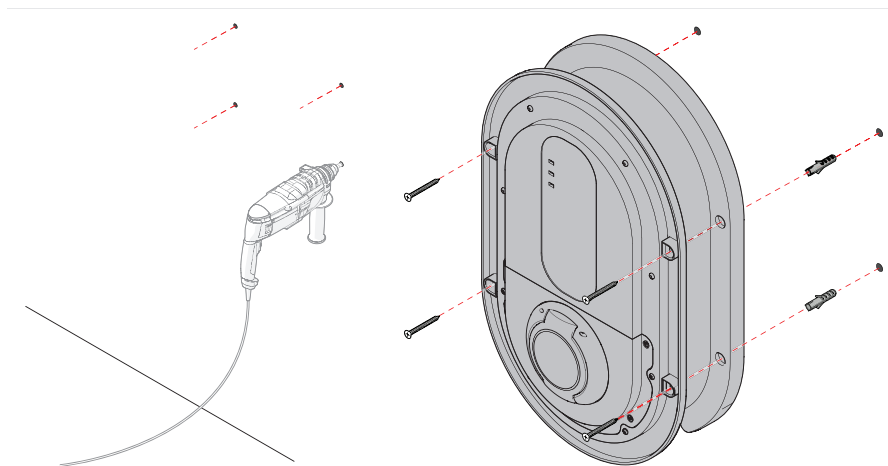

## 5.5. Connect the power cable to the charger

1. Remove the five Torx screws from the housing lid. Use a size T15 screwdriver.
2. Move the housing lid to the side to access the inner circuitry of the product.

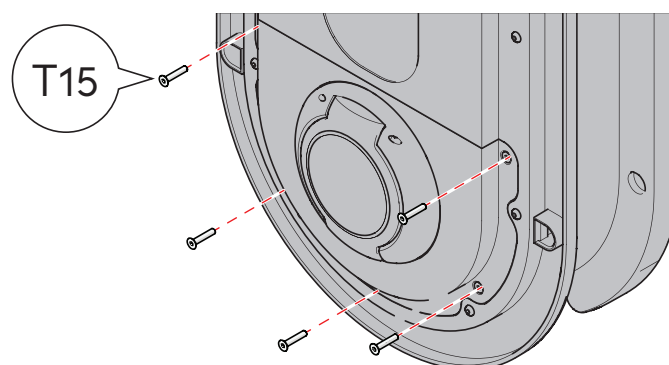

---

3. Carefully remove the left cable inlet cover shown below.

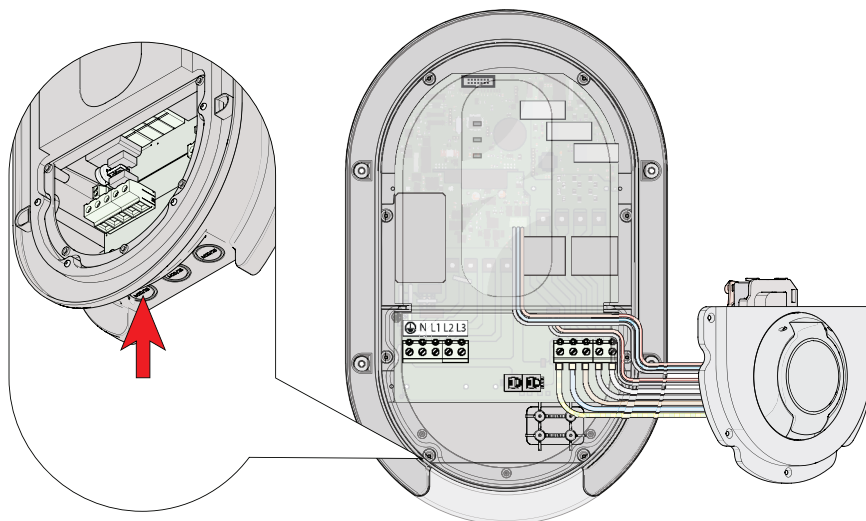

---

4. Insert the cable gland through the left cable inlet.

5. Secure the cable gland with the locknut.

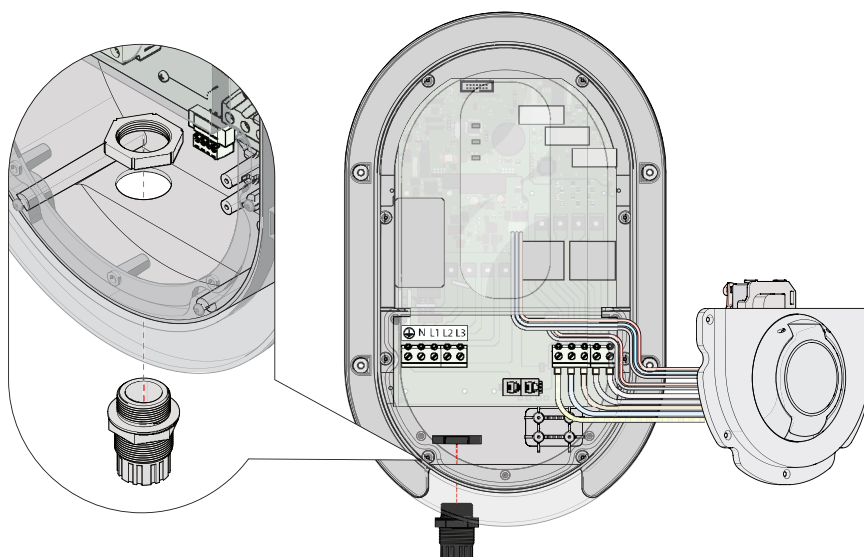

---

6. Guide the power cable through the cable gland.

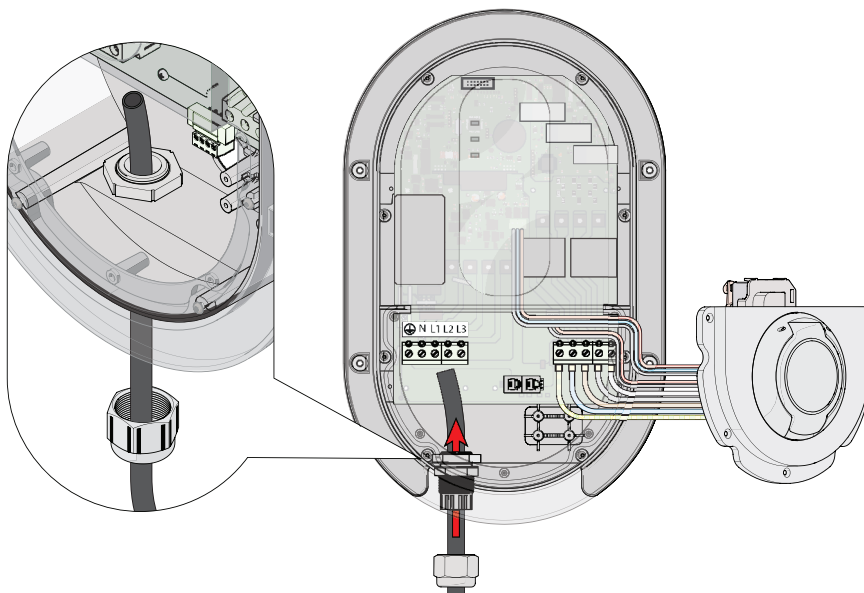

---

7. Strip the wires of the power cable.

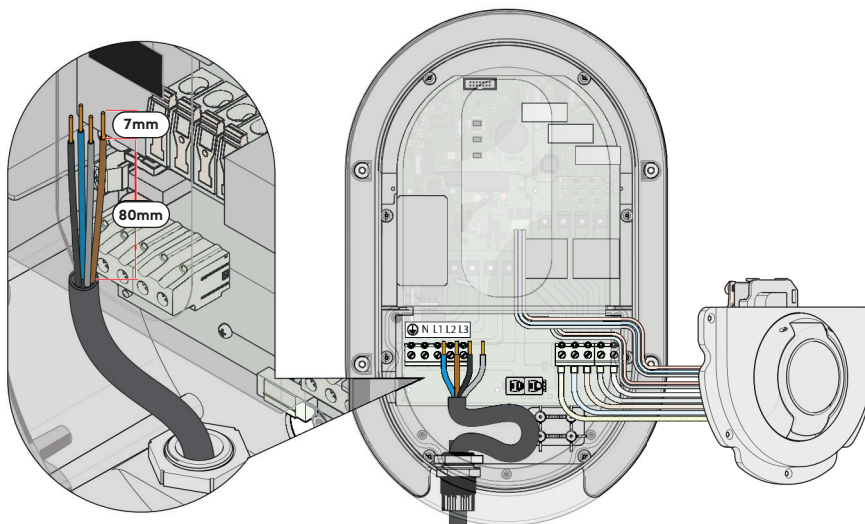

8. Connect the stripped wires to the correct terminals of the left terminal block.

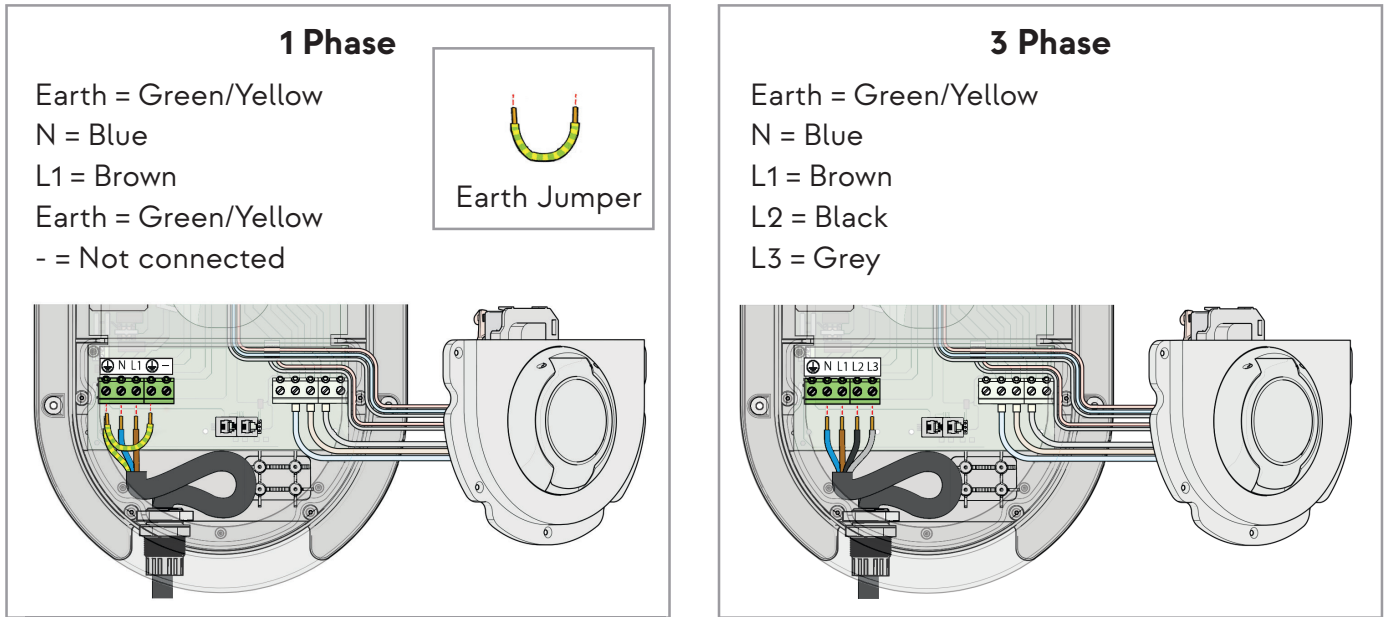

**⚠ WARNING** “Earth Jumper” must **always** be installed for a single phase installation. Never remove this item as it enables the Open PEN fault protection to function correctly.

9. Secure the wires to the terminals using a size 3 flathead screwdriver.

10. Gently pull the excess power cable out of the charger.

11. Secure the power cable in place by tightening the sealing nut onto the cable gland.

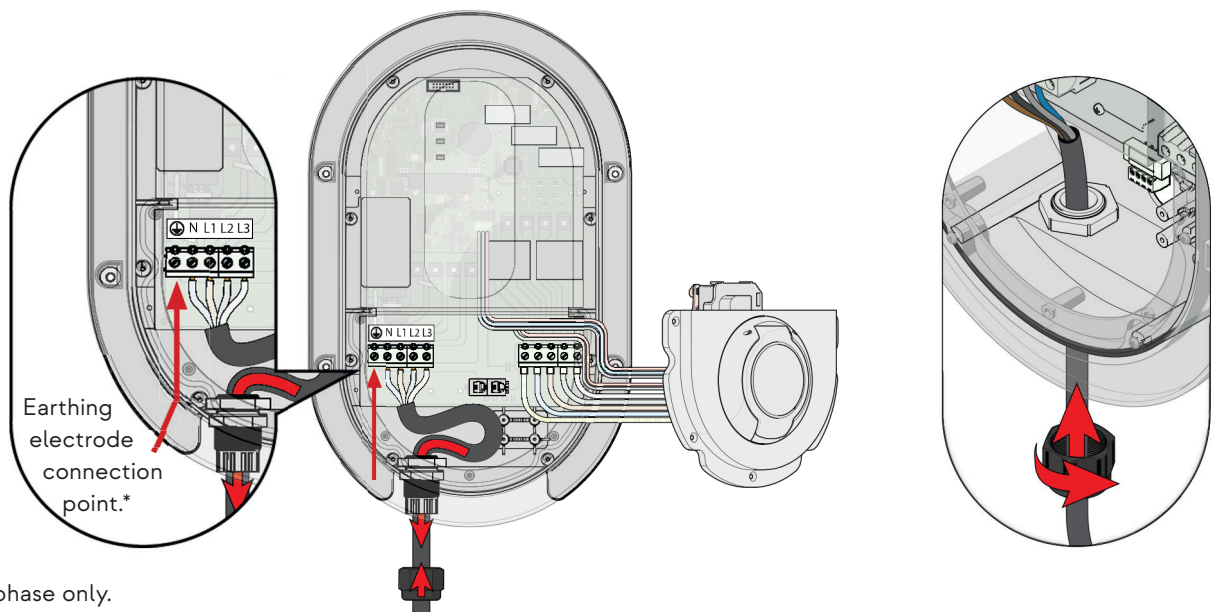

**Note:** Earthing electrode connection required at this stage if a third party open PEN device is not being utilised (three phase only).

Single phase io6 charger variants have an integral open PEN fault device, therefore, no earthing electrode is required. “Earth Jumper” must **always** be installed.

---

## 5.6. Ethernet cable installation

If connecting to Wi-Fi refer to section 6.

1. Carefully remove the centre cable inlet cover shown above.

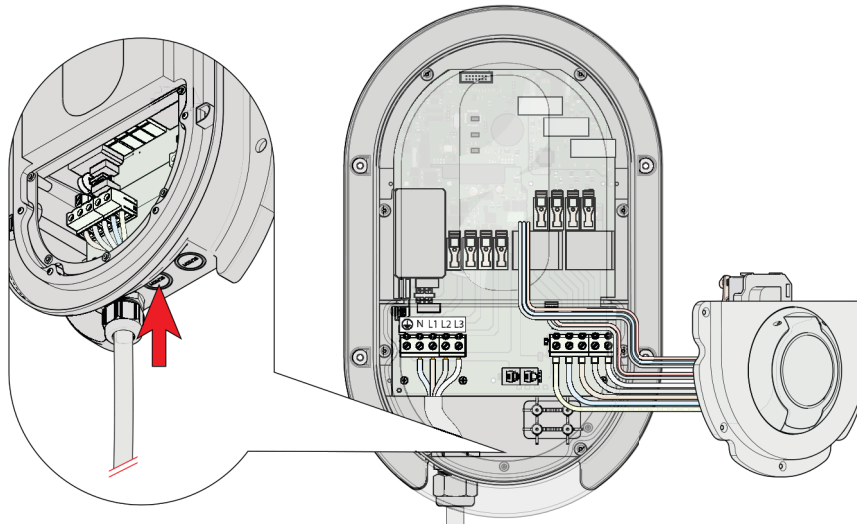

2. Place the insert into the cable gland (select the correct insert as per page 14 (6a, 6b, 10)).
3. Insert the cable gland or rubber grommet into the centre cable inlet.

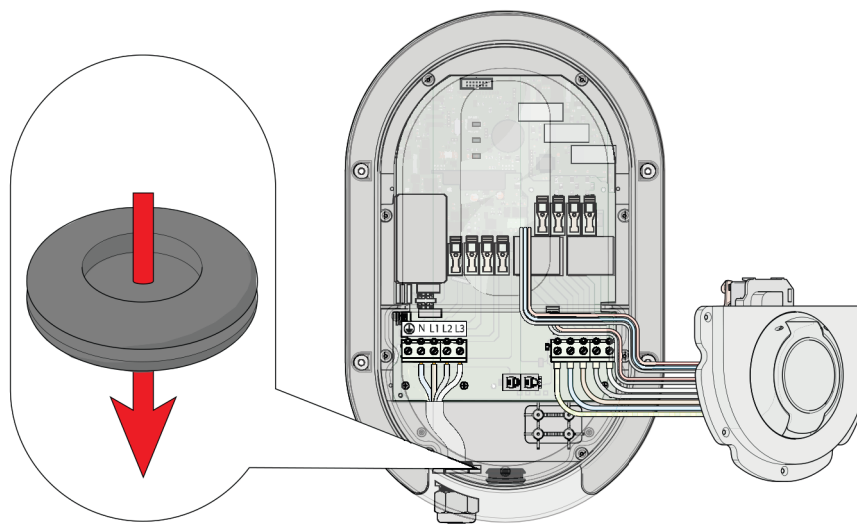

**Note:** When using a wired Ethernet connection, connect an Ethernet cable to the RJ45 socket as shown in the picture below.

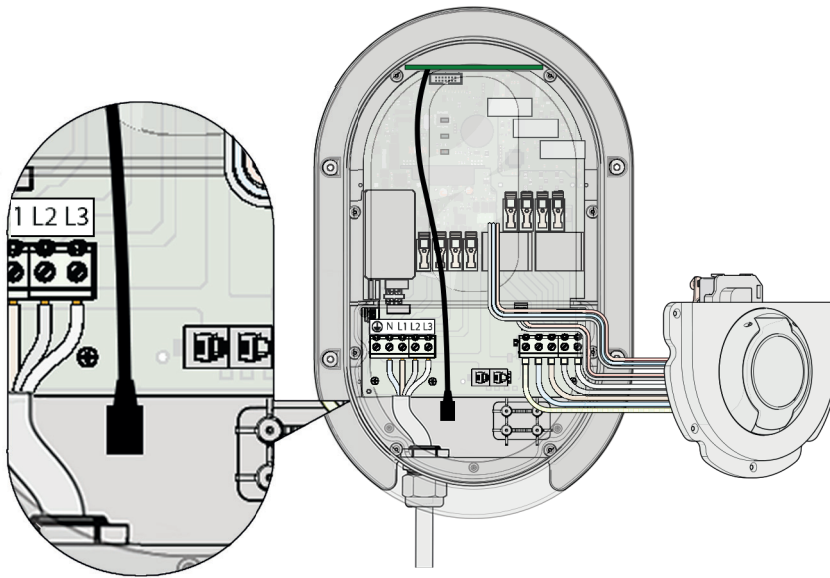

## 5.7. Data cable installation

If not installing a Sensor Box please refer to section 5.9.

1. Strip the wires of the data cable.
2. Take the four full coloured wires.
3. Remove the unused wires.
4. Insert the wires into the RJ10 connector in the exact same order as in the Sensor Box.
5. Secure the wires to the RJ10 connector. Use a RJ10 crimping tool.

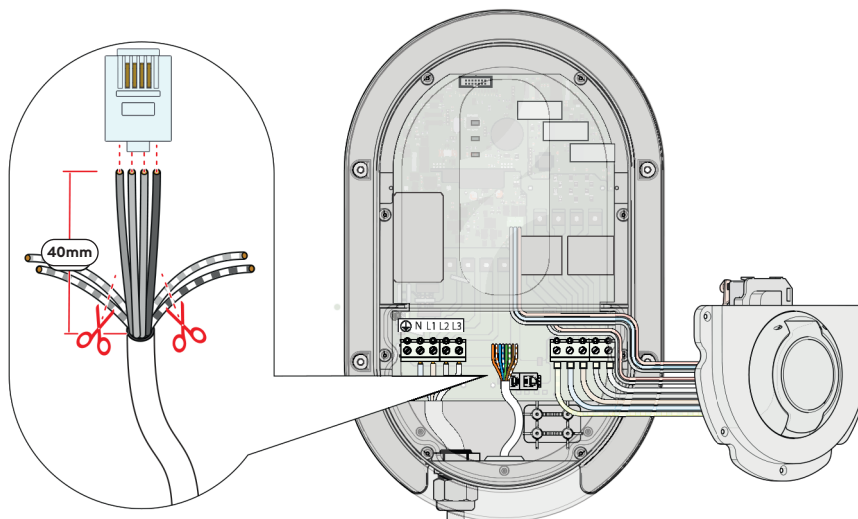

---

6. Insert the RJ10 connector into the left RJ10 port of the charger.

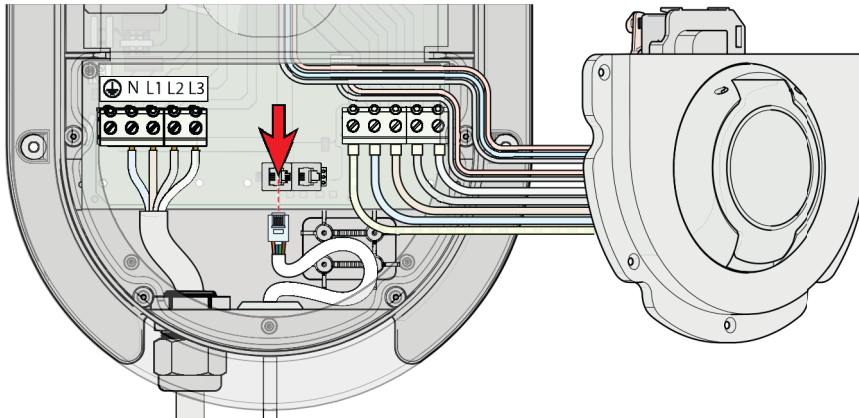

---

7. Gently pull the excess data cable out of the charger.

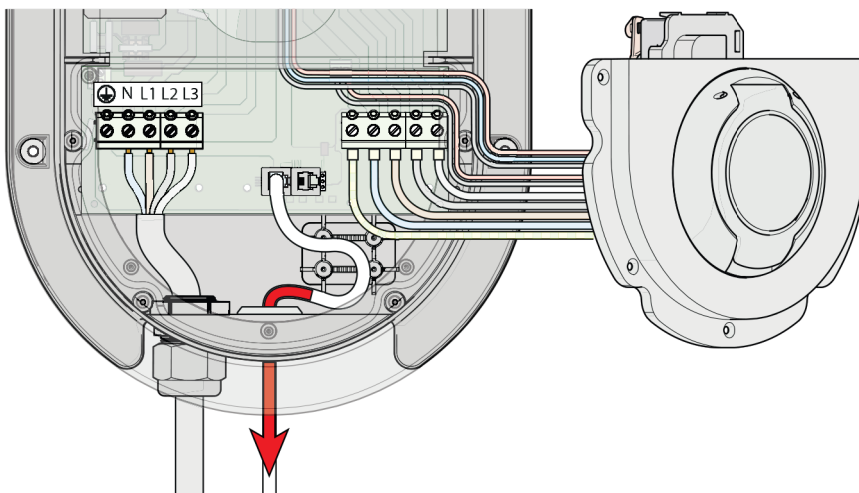

If you have purchased a single charger, please continue to chapter 5.9.

---

## 5.8 Install a data cable between two chargers for Power Sharing

### 5.8.1. In the Main Controller

1. Install a data cable between the “Main” charger and “Sub 1” charger.
2. Remove the terminal connector of the existing data cable from the charger.
3. Guide the second data cable alongside the existing data cable through the cable gland or rubber grommet.
4. Strip the wires of the data cable.
5. Match the coloured wires to the wires already used in the Sensor Box RJ10 connector.
6. Remove any unused cores.

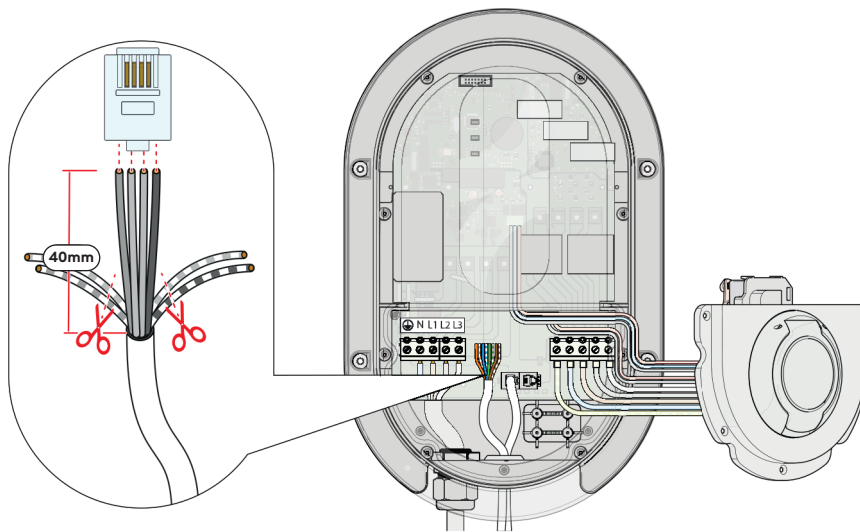

7. Insert the wires into a second RJ10 connector.
8. Secure the wires to the terminals using a RJ10 crimping tool.
9. Insert the RJ10 connector into the right RJ10 connector of the charger.
10. Gently pull the excess data cable out of the charger.

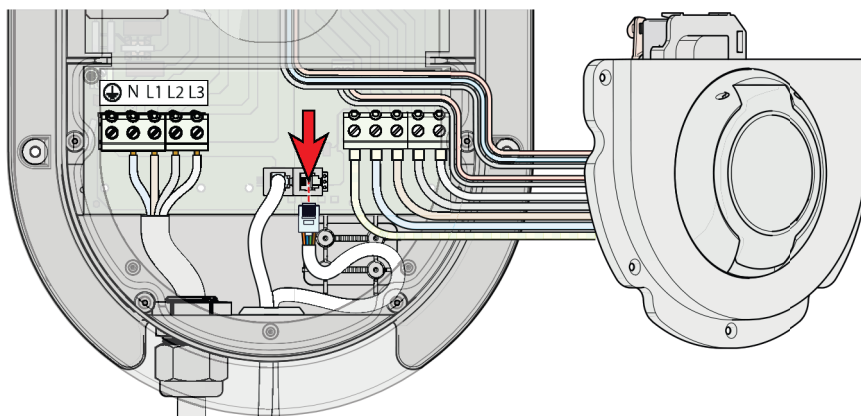

## 5.8.2. In the Sub charger

1. Carefully remove the centre cable inlet cover shown above.

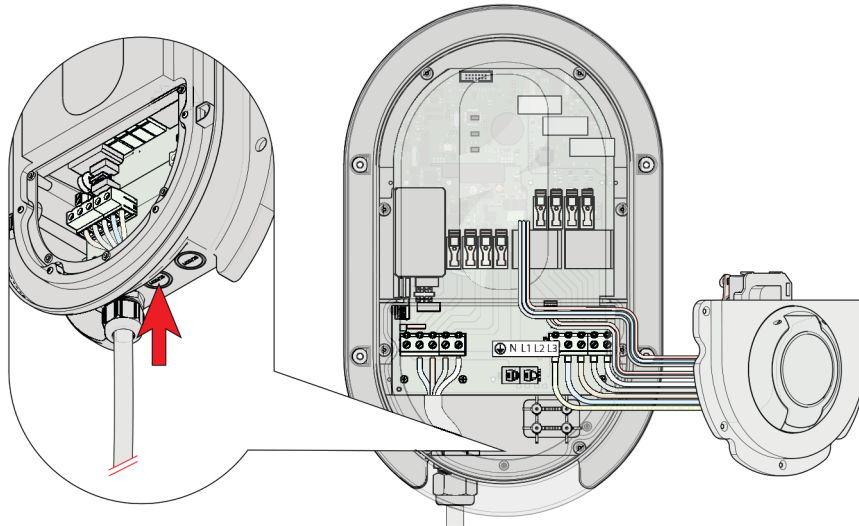

2. Carefully pierce a hole in the centre of the rubber cable grommet.
3. Insert the cable gland or rubber cable grommet into the centre cable inlet.
4. Guide the data cable through the cable gland or rubber grommet.

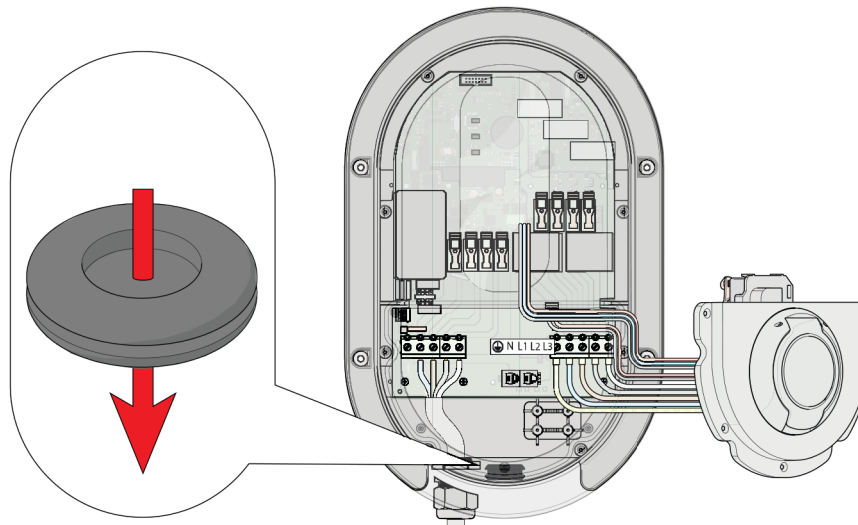

- 
5. Strip the wires of the data cable.
  6. Match the coloured wires of the RJ10 connector on the main charger.
  7. Remove the unused cores.
  8. Insert the wires into the RJ10 connector in the exact same order as in the main controller charger.
  9. Secure the wires to the RJ10 connector using a RJ10 crimping tool.

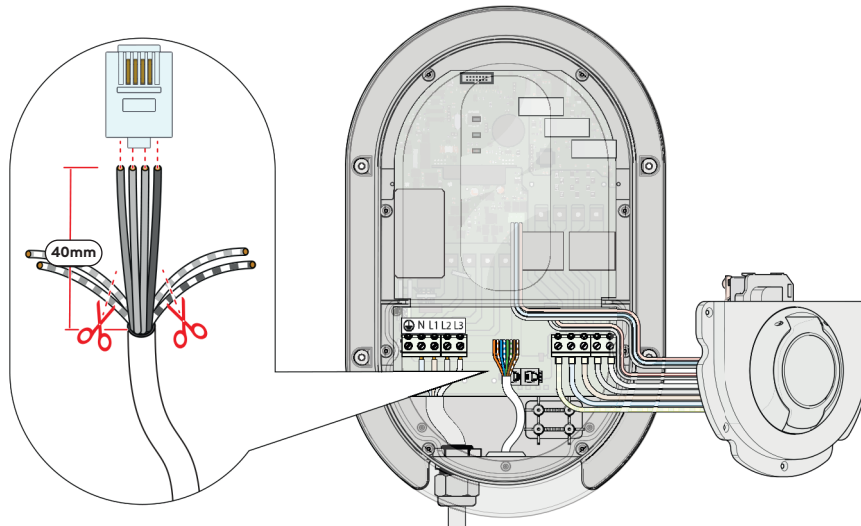

- 
10. Insert the RJ10 connector into the left RJ10 port of the charger named "Sensor Box".

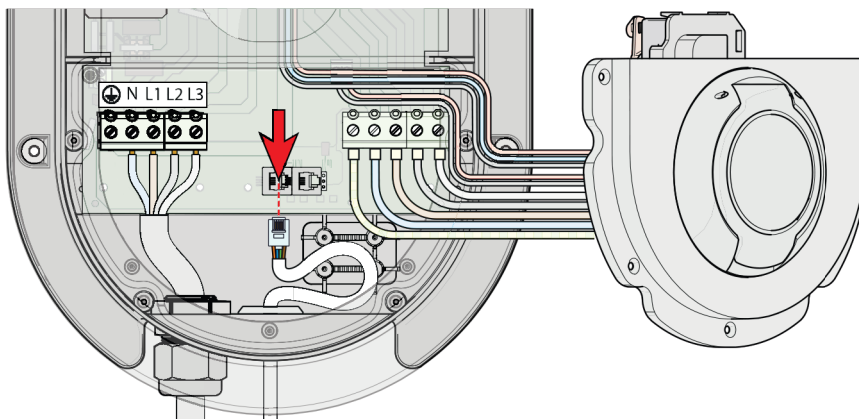

11. Gently pull the excess data cable out of the charger.

12. Repeat the installation steps for sub chargers (maximum of 3 sub chargers) in daisy chain configuration.

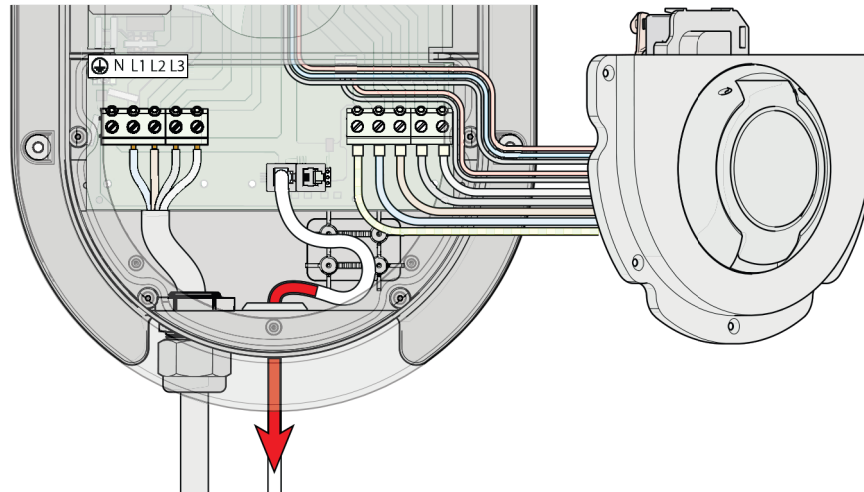

**Note:** Only the Main Controller is directly connected to the Sensor Box.

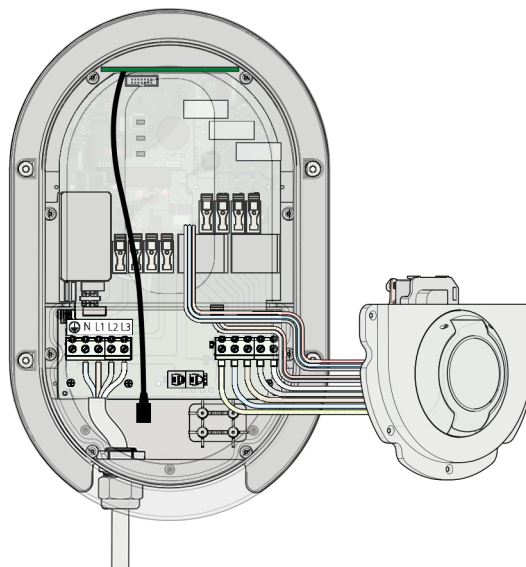

## 5.9. Final installation checks

- Check if all live, neutral and earth wires are properly connected.
- Check if the data cables (if utilised) are wired correctly and the order of the coloured wires match on both sides.
- Check if all cables are free of damage and are properly secured.
- Check if the current transformers (if utilised) are correctly installed onto the incoming phase wires of the main power grid.

## 5.10. Finish the installation

---

1. Secure the housing lid in place with the five Torx screws using a size T15 screwdriver. Do not over tighten the screws. Over tightening screws might cause damage to the housing.
- 

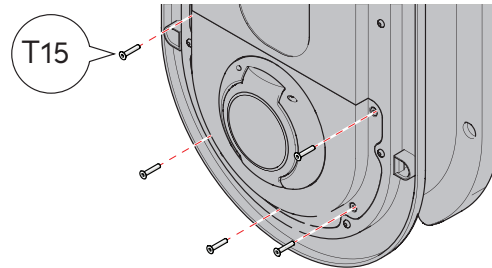

2. Mount the frame on the front of the charger housing. A noticeable “click” sound should be heard.
- 

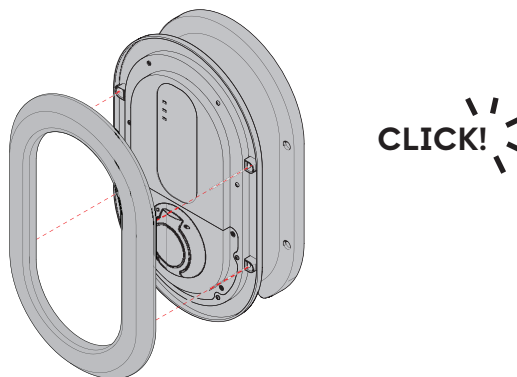

3. Place the fuel identifier sticker onto the front face of the charger (socket versions only) and insert the four screw cap covers onto the mounting screw holes.
- 

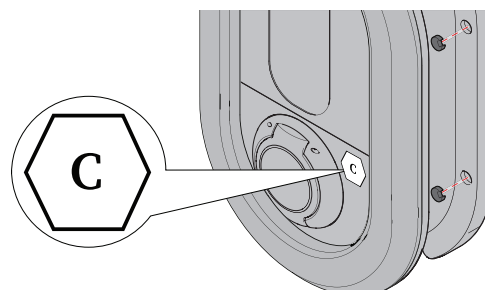

## 6. Commissioning

---

Apply power to the charger. The charger will switch on and boot up will automatically commence. The power LED will light up green to indicate the charger is powered.

The booting sequence is finished when the Charge LED lights up green.

### 6.1. The unique password of the charger

Install the Ratio EV Charging App and create an account before use.

A unique Bluetooth<sup>®</sup> wireless technology password is provided with this charger.

It is important to save this so please ensure to keep this safe along with your installation guide.

This code is necessary if the charger has to be restored to the factory settings. The unique password of your charger is a 6-digit code.

---

### 6.2. Download the Ratio EV Charging App

Install the Ratio EV Charging App and create an account before use.

1. Go to the Google Play store or App Store on your device and search for “Ratio”.  
Alternatively scan the QR code below.
2. Download the Ratio EV Charging App.
3. Follow the steps in the app to login to your account or create a new account. See chapter 6.4. for more information.



**Note:** During the initial installation, the **Advanced settings** menu must be opened and configured accordingly by a qualified electrician.

### 6.3. Initial configuration of the charger

---

#### NOTICE

The **Advanced settings** menu should only be accessed by a qualified electrician. In this menu you can adjust settings that, if entered incorrectly, could damage the installation.

---

Before the charger is ready for use it requires configuration.

---

**Note:** The Open Charge Point Protocol (OCPP) must be connected to a Charge Point Operator (CPO).

To enter the **Advanced settings** menu, select the charger, tap the gear icon at the bottom right corner, and select **Advanced settings**.

**Note:** Entering the Advanced settings menu is only possible if you are within Bluetooth® range of the charger.

**Note:** It is not possible to enter the settings menu during a charging session.

Configure the following settings for the charger.

## 6.4. Step by Step Installation and adding the back-end provider

1. Enable Bluetooth to connect to the charger.

2. Navigate to the “Charger settings” page and add the relevant information to each cell.

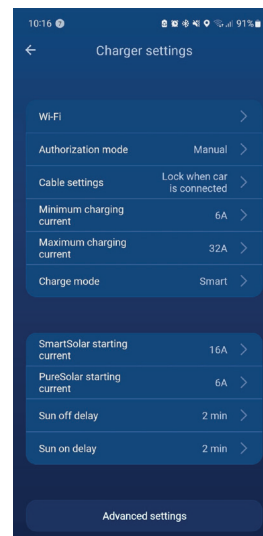
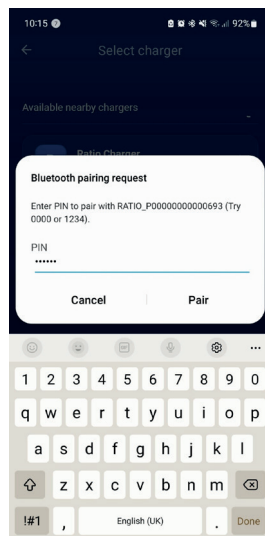

3. Click on “Advanced settings” and add all relevant information to each cell. If using a back-end software provider, toggle on/off the CSMS to add the relevant websocket address and select “Save”.

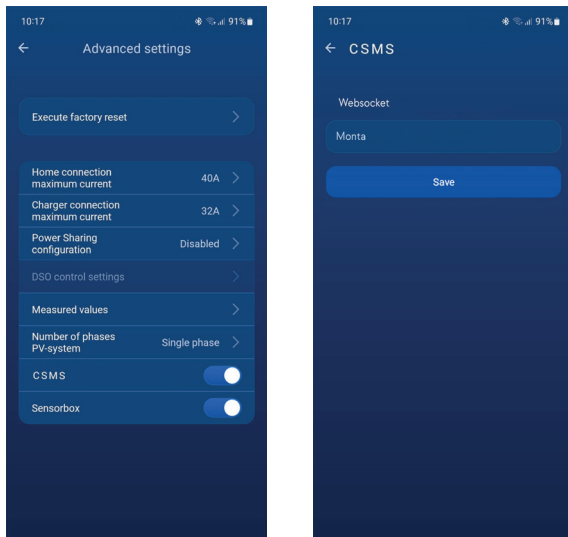

4. Finalise the user settings and click “Start” to begin using.

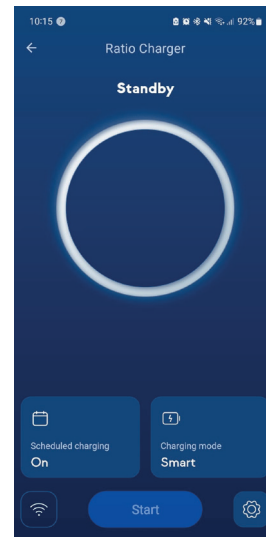

## Power sharing Configuration

If you have a single charger, leave this option Disabled.

If you have multiple chargers interconnected with data cables, activate Power Sharing.

Set the charger that is directly connected to the Sensor Box to: Main.

Available options: Main, Sub 1, Sub 2, Sub 3, Disabled.

**Note:** Make sure every sub charger is set to a unique SUB number.

**Note:** Make sure only one of the interconnected chargers is set to “Main Controller”.

**Note:** PureSolar mode is not compatible with **Power Sharing**. If you enable **Power Sharing**, the charge mode will be set to io6.

## Home connection maximum current

### Single phase

Set this value to the size of the grid connection as measured by the CT clamps. e.g. if the premises has a 1 x 100A connection, set this value to 100A. This value is used for **Dynamic Load Balancing**.

### Three phase

Set this value to the size of the grid connection as measured by the CT clamps. e.g. if the premises has a 3 x 32A connection, set this value to 32A. This value is used for **Dynamic Load Balancing**.

---

---

## Charger connection maximum current

Set the maximum allowed charging current of the charger.  
Range: 6A – 32A.

**Note:** This value must be lower than the rating of the used circuit protection device. i.e, MCB/RCBO.

---

## Number of phases PV-system

Select the amount of phases on which the solar panel installation is installed.

**Note:** This value is only used when the charge mode is set to PureSolar or SmartSolar.

## 6.5. Overview of the Ratio EV Charging App

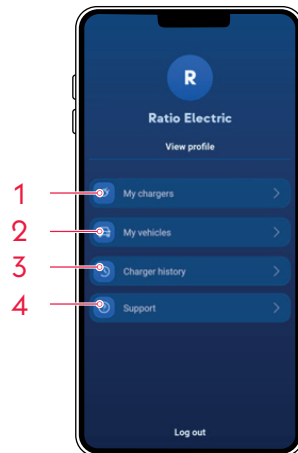

- 1 Manage connected chargers or add a new charger with the unique Bluetooth<sup>®</sup> wireless technology password found on the included label.
- 2 Manage connected vehicles or add a new vehicle.
- 3 Overview of recent charging sessions.
- 4 Shows the current version of the Ratio EV Charging App

**Note:** Adding vehicle information is recommended for a detailed overview of your charging activity.

**Note:** It is not mandatory to register your vehicle, but if you don't register you will miss certain functionalities. Instead of a license plate, you can also enter a name.

## 6.6. Connect the charger to the Ratio EV Charging App

1. Tap **My chargers** on the home screen.
- 2 Tap **Add charger**.  
A list of all available chargers is shown.
3. Check the serial number of the charger on the label and select the charger with the corresponding serial number from the list of available chargers.
4. Enter the 6-digit Bluetooth<sup>®</sup> wireless technology password and press **Connect**.  
If the connection is successful, the charger is now added to the **My chargers** screen.

## 6.7. Testing solar charging functionality

If not applicable, please refer to section 6.7.

1. Temporarily switch off the solar panel installation.
2. Check if the LED on the Sensor Box blinks red three times.
3. In the App, go to the **Advanced settings** and select **Measured values**.
4. Check the values for L1, L2, and L3. The measurements should only show positive values.
5. If any of these values are negative, reverse the CT clamp on the mains incoming cable and ensure all values are positive.  
Points of attention if the App shows incorrect values while the charger is in Smart (Solar) mode:
  - Make sure the arrows on the current transformers point towards the entry point of the main power grid.
  - Make sure the current transformers L1, L2 and L3 are connected according to the phase sequence (Sine).
  - If the charger indicates deviating values, it can help to switch the CT terminals on L2 and L3 on the Sensor Box.
  - The mains input cable of the Sensor Box must be plugged into a power socket connected to the same phase as L1 of the charger.
6. Switch the solar panel installation back on. The Sensor Box will flash in a three phase cycle. It will flash green if there is power generated and being fed back to the grid. The Sensor Box flashes red if no solar energy is being generated (3 x red).  
On a single phase installation, if solar energy is generated and energy is fed back to grid on phase 1, the LED will flash 1 x green and 2 x red in succession.
7. Check if the **Measured values** screen in the App shows negative power values when power is fed back into the grid by the solar panel installation.

**Note:** If no power is currently fed back into the grid by the solar panel installation, perform this test procedure again when there is power fed back to the grid.

## 6.8. Updating the charger

Ratio recommends to always install available firmware updates. Firmware updates keep the data security of the charger up-to-date and occasionally add new features.

Updates are performed sequentially. This allows the system to offer multiple updates in succession. Always install available updates to ensure the use of the latest version. Read the release notes on the Ratio website or in the App Stores to learn about new features and improvements to the system.

Whenever a firmware update is available, the update icon  is shown next to the charger in the **My Chargers** screen.

1. Tap the button for the charger to install the update.
2. Tap **Install now** to install the update or tap **Install later** to delay the update. Delaying the update will allow the immediate charge of the vehicle.

The update announcement reappears the next time you access the **My Chargers** screen.

**Note:** Make sure that the charger stays powered and connected to the internet during the update. Power/network outages can cause the update to fail. The Ratio EV Charging App does not have to remain opened during the update.

While the update is in progress, the icon  is shown next to the charger in the **My Chargers** screen.

The update may take a few minutes. After the update, the charger reboots and is ready to use.

---

**NOTICE** Do not use the charger during the update process.

---

3. Regularly check for available updates in the **My Chargers** screen of the Ratio EV Charging App.

**Note:** Using an old version of the Ratio EV Charging app may lead to compatibility issues and is not recommended.

## 7. Using the io6

---

### 7.1. Start charging through the Ratio EV Charging App

1. Plug your charging cable into the socket of the charger. (socket version only)
2. Plug the other side of your charging cable into your EV.  
The Charge LED lights up to indicate that the EV is detected.
3. Open the Ratio EV Charging App.
4. Select **My chargers**.
5. Select the charger you want to use. The Stand-by screen appears.
6. Select your car or select **Continue without registration**.
7. Select **Start** to commence the charging session of the vehicle.

## 7.2. During charging

During a charging session, the measured power usage is displayed in kW in the Ratio EV Charging App.

### 7.2.1. Charging paused

In case there is less than 6A available on the main grid, the charging session will automatically be paused.

Switch off any power demanding devices or wait until more than 6A of power is available.

As soon as there is sufficient available power, the charging session will automatically resume.

## 7.3. Stop charging

The charging session will stop automatically when the EV is charged to the maximum battery level, set in the vehicle.

You can manually stop the charging session by pushing the **Stop** button in the Ratio EV Charging App or in the back-end app, or by unlocking the vehicle.

1. Unplug the EV charging connector from the vehicle.
2. For socket version: Unplug the EV Charging connector from the charger.  
For fixed cable version: Wrap the fixed cable around the charger and insert the connector into the plug holder on the front of the charger.

## 7.4. Charging Modes

Charging modes will be configured using the back-end software provider, commonly private, public and scheduled charging.

## 7.5 Start Charging App Controlled through back-end software

For guidance on charging your vehicle using a back-end software provider, refer to their website.

## 7.6 Start Charging using RFID

In order to enable users to charge vehicles using RFID, the settings must be adjusted within the back-end software provider and enable the RFID feature.

Once activated, simply plug the charging cable into the io6 and the vehicle, and activate the charging session by swiping your RFID tag.

To begin your charging session;

1. Plug the charging cable into a socket on the io6 (if using a socketed version of io6).
2. Plug the other side of your charging cable into your vehicle.
3. Swipe your RFID tag onto the reader to activate charge. The LEDs on the charger will begin to flash to indicate it has detected the RFID.

## 7.7. Stop charging using RFID

You can also manually stop the charging session by swiping your RFID tag over the reader again.

## 8. Advanced Settings

---

To edit your settings, do the following:

1. Select **My Chargers** on the homepage of the app.
2. Select the charger you want to set up.
3. Tap the gear wheel icon on the bottom right of your screen.

Here you can edit the following settings:

---

<b>Wi-Fi</b>	Connect your charger to a Wi-Fi Network.
<hr/>	
<b>Authorisation Mode</b>	Manual: start charging mode using the app. Auto: start charging mode directly after plugging in your vehicle.
<hr/>	
<b>Cable settings (socket version only)</b>	Select the locking procedure of your charging cable.
<hr/>	
<b>Minimum charging current</b>	Set the minimum required charging current of the charger. Range: 6A - 16A.
<hr/>	
<b>Maximum charging current</b>	Set the maximum required charging current of the charger. Range: 6A - 32A.
<hr/>	
<b>Charge mode</b>	Set the desired charge mode.
<hr/>	

**Note:** See chapter 2. for more information on the charge modes.

---

<b>SmartSolar starting current</b>	Set the minimum required charging current of the charger for the SmartSolar charge mode Range: 6A – 10A.
------------------------------------	---

---

<b>PureSolar starting current</b>	Set the minimum required charging current of the charger for the PureSolar charge mode. Range: 6A – 16A.
-----------------------------------	---

---

<b>Sun off Delay</b>	Set a delay time for the charger to stop charging after net current generation is no longer detected. Range: 2 min – 60 min.
----------------------	---

---

<b>Sun on Delay</b>	Set a charging delay time after net current generation is detected (e.g. from solar panels). Range: 1 min – 20 min.
---------------------	--

---

## 9. Maintenance

---

Ratio chargers are practically maintenance-free, aside from periodic cleaning of the housing.

1. Switch off the charger before cleaning the housing.
2. Clean the io6 Charger using a soft cloth lightly moistened with mild detergent solution.

### WARNING

#### **Risk of electric shock**

- Switch off the charger before cleaning the housing.
- Be careful when cleaning the inlets and socket, do not use excessive amounts of water to avoid water leaking into the charger.

### NOTICE

#### **Risk of damage to the product**

- Do not use aggressive chemicals to clean the charger.
- Do not use coarse cleaning tools that may damage or scratch the surface of the charger.
- Never use any type of abrasive pad, scouring powder, or flammable solvents such as alcohol or benzene.

## 10. Troubleshooting

---

### Troubleshooting using the Ratio App

The charger is equipped with monitoring software that detects faults and displays them as error messages in the Ratio App. Every fault has a specific error code for easy identification. An overview of the error codes is shown below

Error code	Fault	Possible solution
100	Control Pilot (CP) error, faulty values or short circuited. Possible causes: Damaged charging cable, Dirty connectors or Issue originating from the EV.	Switch off the power to the main grid. Clean the connector(s) of the charging cable. Check the cable for any visible damage. Switch the power to the main grid back on. Try charging with a different charge cable. Try charging a different EV. Try charging the EV with a different charger. If the error persists: Please contact Ratio or a qualified electrician to diagnose the issue.
101	Grounding fault Possible causes: Damaged charging cable or Damaged charger	Switch off the power to the main grid. Switch the power to the main grid back on. If the error persists, Please contact Ratio or a qualified electrician to diagnose the issue.
102/103	Maximum temperature exceeded while charging. Possible cause: long, high current charging sessions in high ambient temperatures.	Allow the charger to cool down before resuming the charging session. When the charger has cooled down, the error code should disappear and the charger return to normal operation.
111	No communication between the charger and the Sensor Box.	Check if the connectors are properly inserted in the Sensor Box. Check if the Sensor Box is powered. If the error persists, Please contact Ratio or a qualified electrician to check the Sensor Box connection within the charger is inserted properly.

---

<b>113</b>	PEN Fault detected.	Switch off the supply to the charger and consult a qualified electrician. Do not use the charger until the fault has been rectified.
------------	---------------------	---

---

## Troubleshooting using a back-end provider and App

The charger contains fault detecting software monitored and reported through Open Charge Point Protocol (OCPP) via the back-end software.

If using a back-end provider and are experiencing problems with your charger, please contact the provider to assist and solve the issue.

---

If there is no error code:

- Check the charger, charging cable and connector for any visible damage.
- Make sure the power LED on the charger is on.
- Make sure that the charging cable is properly inserted and locked into the vehicle.

If you cannot find the reason why your charger is not working properly, please contact your local reseller or Ratio EV Charging.

Points of attention if the app shows incorrect values while the charger is in Smart (Solar) mode:

- Make sure the arrows on the current transformers point towards the entry point of the main power grid.
  - Make sure the current transformers L1, L2 and L3 are connected according to the phase sequence (Sine).
  - If the charger indicates deviating values, it can help to switch the CT terminals on L2 and L3 on the Sensor Box.
  - The mains input cable of the Sensor Box must be plugged into a power socket connected to the same phase as L1 of the charger.
- 
-

## 11. Service

---

To avoid risk of electric shock, only qualified electricians should perform service or maintenance on the charger. If your charger is in need of servicing, please contact Ratio, your local vendor or a qualified electrician.

## 12. Data protection

---

We refer you to our privacy statement on our website at [ratioev.uk](http://ratioev.uk)

## 13. Warranty

---

Ratio EV Charging warrants this product to be free from defects in material, manufacture and design for a period of 3 years after the date of purchase. If this product is defective in materials, manufacture or design during this warranty period, Ratio EV Charging will, at its option, repair or replace the product.

Repair parts and/or replacement products may be either new or reconditioned at Ratio EV Charging discretion.

This limited Carry-In Warranty does not include service to repair damage from improper installation, improper connections with peripherals, external electrical fault, accident, disaster, misuse, vandalism, unauthorized alteration or repair, abuse or modifications to the product not approved in writing by Ratio EV Charging.

Any evidence of an attempt to disassemble the io6 charger will void this warranty.

Any service repair outside the scope of this limited warranty shall be at applicable rates and under the terms then in effect.

## 14. Disposal

---



If the charger is defective beyond repair, or you no longer wish to use the charger, please recycle the charger according to Ratio's Terms and Conditions of recycling WEEE products.

## 15. EC Declaration of Conformity



### Declaration of Conformity

**Manufacturer:** Ratio EV Ltd  
**Date:** 01/01/2023  
**Address:** Unit 1 Target Park, Shawbank Road, Lakeside, Redditch, Worcestershire, B98 8YN  
**Product:** iO6 EVSE Charger  
**Model/Type:** IO674SKT, IO674T50S, IO674T75S, IO674T10S, IO674T50C, IO622SKT, IO622T50S, IO622T75S, IO622T10S, IO611T50C

We declare that the above stated product range is in conformity with the provisions of the following statutory requirements, including all amendments, and with national legislation implementing these regulations:

<b>2014/35/EU</b>	LCD - Low Voltage Directive
<b>2014/30/EU</b>	EMC - Electromagnetic Compatibility
<b>2011/65/EU</b>	RoHS - Restriction of Hazardous Substances in Electrical and Electronic Equipment.
<b>EC 1907/2006</b>	REACH – Registration Evaluation, Authorisation and Restriction of Chemicals

All products are manufactured in accordance with our ISO9001 quality system and are 100% tested for safety and operation during production.

<b>Reference</b>	<b>Type</b>
<b>BS EN IEC 61851-1:2019</b>	Electric Vehicle Conductive Charging System General Requirements
<b>BS EN IEC 61851-21-2:2021</b>	Electric Vehicle Conductive Charging System Electric Vehicle Requirements for Conductive Connection to an AC/DC Supply. EMC Requirements for Off Board Electric Vehicle Charging Systems
<b>BS EN IEC 61000-6-1:2019</b>	Electromagnetic compatibility (EMC). Generic standards. Immunity standard for residential, commercial, and light-industrial environments
<b>BS EN IEC 61000-6-3:2021</b>	Electromagnetic compatibility (EMC). Generic standards. Emission standard for equipment in residential environments

Name and signature of authorised person

Tom Jennings – General Manager





## UKCA - Declaration of Conformity

**Manufacturer:** Ratio EV Ltd  
**Date:** 01/01/2023  
**Address:** Unit 1 Target Park, Shawbank Road, Lakeside, Redditch, Worcs, UK, B98 8YN  
**Product:** iO6 EVSE Charger  
**Model/Type:** IO674SKT, IO674T50S, IO674T75S, IO674T10S, IO674T50C, IO622SKT, IO622T50S, IO622T75S, IO622T10S, IO611T50C

We declare that the above stated product range is in conformity with the provisions of the following statutory requirements, including all amendments, and with national legislation implementing these regulations:

<b>UK SI 2016 No. 1101</b>	The Electrical Equipment (Safety) Regulations 2016
<b>UK SI 2016 No. 1091</b>	Electro Magnetic Compatibility Regulations 2016
<b>UK SI 2012 No. 3032</b>	Restriction of the use of Certain Hazardous Substances in Electrical and Electronic Equipment Regulations 2012.

All products are manufactured in accordance with our ISO9001 quality system and are 100% tested for safety and operation during production.

<b>Reference</b>	<b>Type</b>
<b>BS EN IEC 61851-1:2019</b>	Electric Vehicle Conductive Charging System General Requirements
<b>BS EN IEC 61851-21-2:2021</b>	Electric Vehicle Conductive Charging System Electric Vehicle Requirements for Conductive Connection to an AC/DC Supply. EMC Requirements for Off Board Electric Vehicle Charging Systems
<b>BS EN IEC 61000-6-1:2019</b>	Electromagnetic compatibility (EMC). Generic standards. Immunity standard for residential, commercial, and light-industrial environments
<b>BS EN IEC 61000-6-3:2021</b>	Electromagnetic compatibility (EMC). Generic standards. Emission standard for equipment in residential environments

Name and signature of the authorised person

Tom Jennings – General Manager







Ratio EV Charging,  
Unit 1 Target Park,  
Shawbank Road,  
Lakeside,  
Redditch,  
Worcestershire  
B98 8YN

+44 (0) 1527 396 900  
[ratioev.uk](http://ratioev.uk)  
[info@ratioev.uk](mailto:info@ratioev.uk)